



Wood Words

Kansas City Woodworkers Guild www.kcwoodworkersguild.org

Volume 22 Issue 7

August 04

Guild Meetings:
Jacob's Well Church,
1617 W. 42nd St.,
KC Mo. 64111

Balance of Wood Magazine trip fee due at August meeting

DIRECTORS-OFFICERS:

President: Wayne Wainwright
816 453-1073
wrrig@kc.rr.com

Vice President: Wayne Suter
816 628-4602
wlsuter@earthlink.net

Secretary: Dave Roth
913 338-2433
chefroth@everestkc.net

Treasurer: Paul Twenter
816 781-9407
paul@twenter.com

Events: Mike Jones
816 204-6406
sportsturf@kc.rr.com

Communication: Brian Kemp
816 455-8892
b.kemp@earthlink.net

Sponsorship: Neal Shoger
816 781-4000
nrshoger@swbell.net

Membership: Terry Stair
816 765-7296
tandkstair@aol.com

Training: Ken Sokol
913 441-6060
kensokol@yahoo.com

Education: Chuck Slagle
913 402-8336
slaglecs@earthlink.net

Video
Don Kruse

Books
George Rexroad

Editor/Web:
Wayne Wainwright

August Raffle: Chris will have his usual assortment of fine tools!

Please thank sponsoring members; noted below for supporting our Guild.

Next Meeting Wed. August 18th, 7 PM

Program: Dovetail Joinery: with Mac Dressler

Sawdust: The Presidents Corner

Wayne Wainwright



Time must be flying! Can you believe we have reached 20 years of age?

Yes, the **Kansas City Woodworkers Guild is 20 yrs old this year.**

This is a significant accomplishment. The Chamber of Commerce says that 1 in 7 businesses and only 1 in 10 Non Profit organizations last more than 3 years in existence!

The date has not been set, but in celebration, we will host a cookout. You and your family will be invited to enjoy food and drink in what I hope will become an annual event to celebrate our friendship. As soon as a date has been picked, we will make the announcement.

Now, to business. In-

creased membership, fiscal responsibility, Mentor Workshops, CRP, Surveys, Leadership Development, Improved sponsor relationships, Training classes and Community involvement.

Sounds like a lot? It is, and it is what has been done so far this year by our leadership team.

They are rolling ahead with trying to improve the direction and focus of our guild - with one ultimate goal. Making this a better place for "you" as a member.

I believe the 2 keys to our future success are education and contribution. Teaching woodworking and sharing our skills with others - whether they are members of the Guild or not - is what will drive us to meeting our goals.

5 of our members stepped up to the personal appeal I made last month.

Later this year, we will begin what I hope will be a long lasting relationship with TRI (The Rehabilitation Institute) and will provide training programs for the Kansas City community at the

PLEASE PATRONIZE OUR SPONSORING MEMBERS



Paxton Woodcrafters
(816) 483-0659



PlansNow
www.PlansNOW.com



Schutte Lumber
(816) 753-6262



Turn-About-Wood
(816) 587-3195



Woodcraft Supply
(913) 599-2800



Elmwood Reclaimed Timber
(816) 532-0300



Professional Tool Mfg LLC
(913) 599-2800



Accent Merchandising
(816) 635-5792



The Framery
(913) 831-9411



Strasser Hardware
(816) 236-5858



Liberty Hardwoods
(816) 231-0852



Wood By Design
(913) 962-0159

Downtown Library.

In addition, we are providing regular “training” sessions for our members through the Mentor sessions and specialized training classes.

I thank all of you for supporting these efforts and improving the Guild overall.

Woodcraft has given us several Saturdays throughout the year to conduct toy building programs. Terry Stair conducted the first one on July 31st. I appreciate all who participated and look for greater involvement going forward. Look for additional opportunities to be announced in August.

Let me be the first (and hopefully not the last) to welcome our newest Sponsor - Wood By Design owned by member Russ Amos. This is an important “win” for the Guild as Russ has also been a long-time participating member and is increasing his level of support of the Guild in this special way. Thanks Russ.

We are now up to 12 Sponsors and our membership has grown by 28 new members so far this year. All of this says that we are heading in the right direction. We were even contacted by an individual from Salina KS. about becoming a member. He was intrigued by what he read on our website.

I hope you are all using your Guild business cards you received last month to recruit your friends and family to become members of the Guild.

As you may know, as an incentive, we are offering raffle tickets for bringing in someone and more for signing them up - see the “rules” posted at the sign-up desk at each of the Guild monthly meetings. Did not get your cards? See Terry Stair at the next meeting you attend.

As I mentioned in June, I see all of you as the great “engine” for growth and hope everyone

participates in helping to make our Guild a place we can all say “I am proud to be a member”.

The Tool Auction has been moved to October 16th to allow more time to coordinate and make this a memorable event. Your leadership team is working tirelessly to make sure this goes over well.

This month, we need to vote on the By-laws that were introduced in July. Everyone in attendance will have a vote and as per the By-laws, the majority of voters in attendance will decide the outcome. Based on member feedback, a change was made since the last distribution. In the “By-Law Revision” section, the last sentence was revised as follows: **“A majority vote of the membership present at that meeting is required for passage”**. Originally the text referred, in error, to the “Leadership Team” rather than the “Membership”.

I am excited about this as the By-laws will give us a consistent set of guidelines by which to operate our Guild and will allow us to introduce a certain consistency of understanding when new members join.

During last months program, Cliff Bell gave an excellent review of his trip to the Windsor Institute with famed woodworker Mike Dunbar. However, we had some technical difficulties with the presentation and many of the pictures could not be reviewed. We will ask Cliff if he is interested in redoing the presentation at a later time so that you can get the full sense of this really good program.

These are exciting times for our Guild and our future looks bright. I hope you can feel the momentum as we begin to change for the better. I believe 2004 is the start to something great for us and I almost cannot wait for 2005 and beyond.

It takes time to make significant process change but we are determined to do just that. All the things that are good about our guild - the camaraderie and friendship - will continue. We are trying to balance growth with values which is why we must have the guiding light of the By-laws and the full participation of our membership and I will endeavor to ensure that what was, does not change as we go forward.

Program: Bob Settich - Tuning the Drill Press and Cliff Bell - The Windsor Chair

David Roth

Bob Settich gave a program on tuning up your drill press. Bob brought in his Delta 16" drill press to show us how he tunes it up. The goal of the program was to improve accuracy in three ways:

- Reducing vibration
- Lubrication to reduce friction and wear
- Adjusting excessive play out of the quill

Bob passed out sheets on this procedure. If anyone wants a copy they will be available at the August meeting.

Cliff Bell talked about his trip to the Windsor Institute and what he did to produce a Windsor chair.

Cliff went to Silver Dollar City last year and saw someone make a Windsor Chair, and he spent about a day and a half looking at how to make the chair. He told cliff "if you really want to do this right, you might want to go to the Windsor Institute and spend a week learning how to build this type of chair".

So Cliff went to Hampton, New Hampshire to the Windsor Institute to learn how to build one of these chairs with Mike Dunbar.

It is a 5 day course 8:00 a.m. to 4:30 pm. There are about 16 people in his class. The cost of the class was around \$650.00. That's not including the tools you need to make the chairs. The classroom has all of the tools to build a chair. But Cliff liked to have his own tools handy when he needed them.

Mike Dunbar has about 12 different designs of chairs. But you first have to take the class on how to build a basic Windsor chair before you can move on to the other designs. He shows you how the chair is made the way

they made the chair in the sixteen hundreds. All of the wood was already there ready to go. That is, the wood was already pre cut.

The Chair that Cliff did was probably made in the seventeen hundreds and was introduced in Philadelphia as a garden chair.

The chair is made from different kinds of woods. The seat is made from white pine. The spindles are made from red oak - you could use hickory - and the legs are made from maple. The legs for this class were pre-shaped.

When people made these chairs in large quantities, the chair maker would hire someone to make the legs and they would have other workers do a specific job on the chairs. Then they would have an apprentice carve the seat out.

One of the tools you will need is a spoon bit and this is drilled by hand. Spoon bits run around \$175.00 for a set of four.

The chair is made basically with hand tools. Everyone in the class has a completed chair the last day of the class. They made the arms of the chair and the back of the chair with a spoke shave to round the wood.

(Continued on page 4)

Special Member Benefit from:

Plans NOW

Join the PlansNOW Treasure Hunt and win TOOLS! Visit PlansNOW.com and click on the PlansNOW Pirate for details.

And while you're there, use your 15% discount on all the plans and techniques in the store.

(Continued from page 3)

They explain in class how to best bend the wood by the way you split the wood.

They had a steam machine to heat and bend the wood. It was made from 6" PVC pipe. And it only takes about ten minutes to heat up the wood to bend.

They chop the seat with an ax to give it a rough shape then they finish the seat with a draw-knife. They also taught cliff how to use a spoke shave and how to make fine cuts with a spoke shave.

Cliff used his spoke shave to make all of his spindles. The spindles must have a good tight fit for the chairs and they have a template to determine how thick the spindles should be.

The angles are very important when making these chairs. The more you sit in a Windsor chair the stronger it gets.

The chair has no hardware to it. Just wood and white glue.

On top, the chair spindles have been split and a wedge put in to hold the spindles in. These chairs were also made from green lumber. Only the legs and the front spindle are of dry wood. .

On top, you have to drill holes 7/16" in width in a 3/4" piece of wood. So cliff had to fasten a C clamp to the wood before he drilled his holes so he didn't split out the sides.

The instructors show you what they want you to do. When the instructor gets done then it is your turn to do it.

Cliff is planning on taking more classes in New Hampshire!

**Thanks Bob and Cliff
for an excellent program**

Web Words

Wayne Wainwright

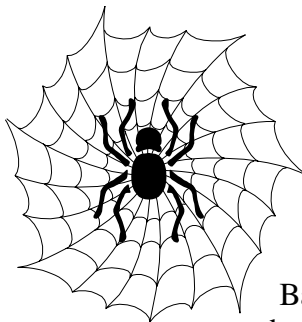

Web site: There were not many changes to the web site this month.

Based on feedback from our members, a few changes were made to "clean up" navigation. You will now find a link to the current months newsletter on the front page of our site.

As we learn and grow, some of the current links may change. You will always find updates here in the newsletter AND on the web.

As promised, a "site map" has been added to the bottom link on our website. This should help visitors find the information they are looking for quickly and with fewer "clicks" making it easier to navigate through our site.

If there are things you would like to see added, or modifications made to existing items on the site, feel free to send an email to the webmaster at:

webmaster@kcwoodworkersguild.org



Work still in progress

Book Reviews

Dave Kraatz

A Fun to Read Book of Woodworking Wit and Wisdom

I am a greedy reader of all types of books, particularly those on woodworking, but I have to admit that many are ... well sort of dry.

They are good instruction and serve to teach us new techniques but they leave out the personality of the writer. I have found the unique exception to this in **Woodworking Wit & Wisdom , Thirty Years of Lessons from the Trade** by Jim Tolpin.

This book is a delight to read because it is simply sixty short lessons or essays on his learning experiences as a professional woodworker.

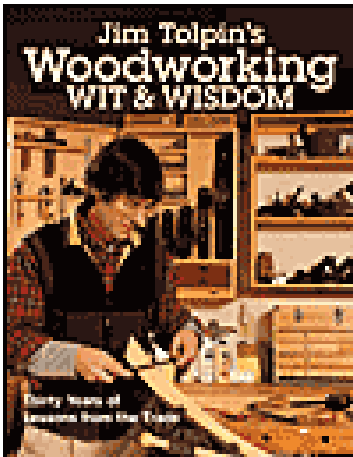

You will learn from him many old tricks of woodworkers that will make your work more fun, more efficient and better overall.

I was intrigued by the back cover which I think sets the stage for the whole book. The following “did you know?” questions are posed;

- The three most fundamental and essential tools can't be bought
- Sanding is the slowest, most tedious and most counter productive way to prepare a surface for finishing
- The absolute strongest bends are made without bending the wood
- A scrap of tar paper and a chunk of scrap wood comprise one of the most precise layout tools available to a woodworker

- There is no such thing as a mistake in woodworking

If you are jumping at the chance to learn the answers, you must read this book. There are no plans or projects, just plain time honored woodworking technique. Through this book, Jim Tolpin can become your new woodworking “Best Friend”.

An Excellent Router Book

I think that most of us as woodworkers own and use routers very frequently, but we always think that there may be a few more tricks that we would like to learn.

I think that the new book **Working with Routers** one of The New Best in Fine Woodworking Series

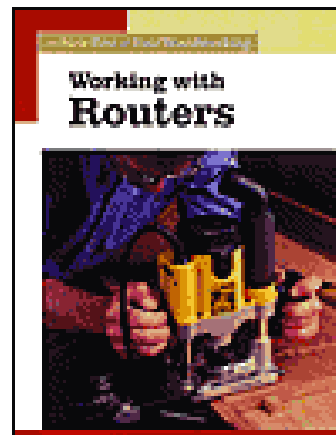

from The Taunton Press can propel you to new proficiency in your router work.

This book is an all encompassing approach to router technique by the Editors and Contributors to **Fine Woodworking** magazine.

There are several designs for router tables, multiple techniques for mortising, a way to build your own dovetail jig and a good grounding in template routing. If you are a new woodworker, this book can give you a head start in learning how to use the most versatile of woodworking tools.

If you are a seasoned woodworker, you already know the value of a router, but this book can certainly add to you skill and expertise. Give this book a good look. You may find new uses for your router and possibly find an excuse to own more than one or two orseveral.

As usual, these book reviews can be found on the website as well as a link to Barnes and Noble to purchase them if you like.

Shop Safety

Brad Barth

When I was a teenager I was doing odd jobs one summer building room partitions in a warehouse. While trimming a 4" X 8" piece of wall paneling that was laying on two saw horses, I was holding the circular saw in my left hand, (I'm right handed) and supporting the board with my right hand.

I was in a hurry to take my lunch break. My right hand fingers were wrapped under the panel while I was concentrating on following the scribe mark with the saw in my left hand. I cut past my right hand and took off the first joint of my pointer finger, that was under the panel, and cut into the next finger also. About an inch of finger went flying across the room. That was about 30 years ago and the finger reminds me everyday.

Advice to other woodworkers

Don't do a right handed job with your left hand and visa versa. Never be in a hurry when using power tools.

Needing to cut only 2" from a 2 x 4 which was only about 4' long, I set it on the floor and kneeled behind it. Cutting with my right hand only and holding the wood with my left, the saw kicked back and buried itself into my right thigh. Cutting diagonally about 6-7" across just above the knee cap down to the bone. It took about 130 stitches in and out and 10 weeks off work and 8 weeks of rehab. The funny thing was a table saw was about 8 feet away but I was in a hurry. Never ever hurry!! It's not worth it

Advice to other woodworkers

If you catch yourself combining power tools along with hurrying, stop and think about the consequence. I know now!

While crosscutting a piece of wood free hand with a worm-drive Skill saw, a knot was encountered causing the saw to pause in its forward motion. In pushing harder I unconsciously straightened the index finger on my left hand so that when the saw progressed through the board it removed the pad area of said index finger plus a little bit of the bone.

Advice to other woodworkers

Be more careful

Printed by permission of: Woodworking.org.
All Rights Reserved. For more tips like
this, visit www.Woodworking.org

2004 Guild Activities

Mentor Sessions

- **Jim McCord:** Boxes - August 21
- **Jerry Jennings:** Lap Joinery - August 28
- **Don Inbody:** Tea Caddy - September 4

Anniversary Cookout

- The Guild is celebrating it's 20th anniversary this year. A cookout is being planned a little later in the year. All members are invited to join in the fun. As soon as a date has been selected it will be announced.

Bus Trips

Wood Magazine:

- The balance of the fee (\$20 if you paid last month, \$30 if not) for the October trip is due at the August meeting. This is the final payment prior to the actual trip.
- A trip to the Amana colonies is being planned. Dates and costs will be published in the newsletter when available.

Tool Auction

- The Tool Auction has been moved to October 16th to allow more time for coordination.

Kansas City Library

- The Guild has been invited to put on a "program" at the Kansas City Library downtown branch in the new location on 10th street. The classes will be held in October 2004. They will consist of a 1 hr session on how to build small items such as a bird house, small box etc.

TRI

- We have gotten the volunteers needed to assist TRI in their effort to start up a "production" shop making small woodwork-

ing items. The Guild will provide assistance in this endeavor and hope to have them up and running this fall.

Toys

- Terry Stair conducted a toy building session at Woodcraft on July 31st. Parts were cut and sanded for about 40 toy benches. Terry was very please with the result and hopes to have about 100 toy benches built this year. We appreciate the efforts of everyone who participated.

Member to Member

Wayne Wainwright

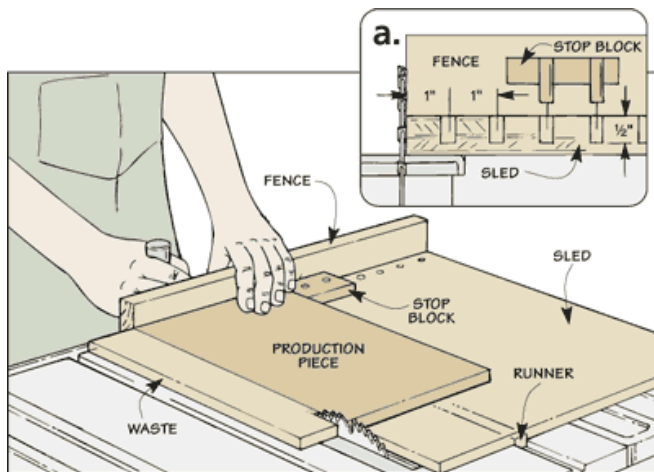

I've been making and selling the same wood items for fifteen years.

In order to speed up the production process, I came up with this method for creating duplicate parts without having to re-measure every time I need to make a run of a certain part.

My trick is to use a crosscut sled with stop blocks that automatically set up the work piece for the cut I need.

I started by making a simple crosscut sled for my table saw. It's nothing more than a piece of plywood with a fence and a runner.

Then I drilled a row of evenly-spaced holes in the sled, just in front of the fence, as you see in the drawing.

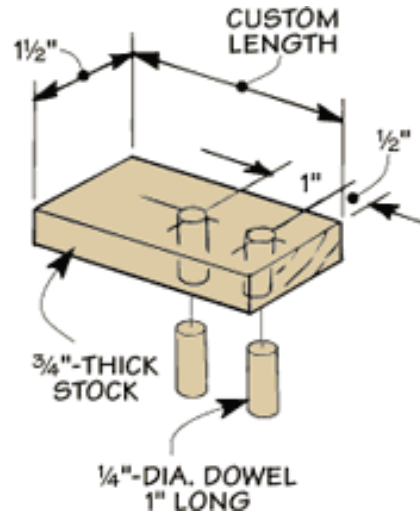

Each stop block is just a scrap of wood with a couple of dowel pins glued into holes drilled in the block (see drawing at left). The dowel pins are

spaced to match the hole spacing in the sled.

I make a custom-sized stop block for each part that I create. Then I label the stop block so that I know what part it's for and which holes it fits into on the sled.

Whenever I need to make more of a certain part, I simply grab the particular stop block and mount it to the sled. This way I always know that the pieces will be the same size.

Printed by permission of: © August Home Publishing Co.
All rights reserved. For more tips like this, visit:
www.WoodworkingTips.com

Want to help cut guild monthly costs? Consider receiving the newsletter via email. It is faster and comes in color. If you are interested, please send an email to Wayne Wainwright at: wwrig@kc.rr.com, or add your email to the Attendance list at the monthly meetings.

Newsletter Deadline: 1st of the month:

**Please send all submissions for articles, tips, want ads announcements and anything else to Wayne Wainwright:
816 453-1073 email: wwrig@kc.rr.com**

4214 N Brighton Ave KC. MO. 64117

Member of the Month

Brian Kemp

Jerry Jennings



What is your specialty in woodworking?

Sawdust is my largest specialty and on occasion, a table, shelving or cabinets comes out.

How many years have you been woodworking?

About 27 years.

What is your favorite

hand tool and why?

I rarely use any hand tools but I guess it would be a plane and chisel. You can “fine tune” your project very closely.

What is your favorite power tool and why?

Table saw and Router! You can cut nice straight lines with the table saw and then rout them to take away the “home made” look.

What is your favorite wood to use and why?

Oak and Walnut. Oak is easy to work and takes a very nice finish. Walnut does this too but the dust goes everywhere!

What is the favorite project you have built and why?

Replica of an antique pie safe from white oak. It was my first large piece and it turned out fairly well.

What is your best deal on a woodworking tool?

My Porter Cable orbital sander I won at the Guild raffle.

What guild activities have you been involved in?

10 - 12 years in the Toy Project, Flag Boxes, and the Tool Show. Perhaps more, but I don't remember now.

What has been your favorite guild activity?

Helping assemble the toys and see them all together, then seeing all the “Thank You” letters come in.

What Shop Tip can you give us?

“DO NOT” try to run a short board through a jointer planer bare handed. I assure you, the jointer cuts fingers into the same small pieces as it does a board!

Thanks Jerry for allowing us to feature you and your work this month!



Show & Tell - Show Pictures



Jim Ramsey Combo Stand



Jim Childress Bird Houses



Wayne Wainwright
Flag Case and Blocks



Russ Amos Kitchen Cabinets



Jim Bany Small Parts Bin



Unknown



Kevin McAndrew "Timeout" Bench



P.O. Box 413922

Meeting Minutes

New members: Dave Deucher (Wainwright) Phil Graham (Twenter) Don Spears (Self)

News:

- Someone donated a new P.A. audio system and a Dell projection system to the Guild. Both items are worth over \$1,000.00 each. We thank the anonymous donor!
- On July 7th an Editor from Fine Woodworking met with our guild members. We learned how they do things in their magazine and we discussed how our members could contribute to the magazine.
- Treasurer Paul Twenter reports we have \$3,534 in the bank
- Auction moved to October 16th.
- Paxton donated 25 videos to the Guild
- George Rexroad donated the book he won to the Guild Library. Thanks George

Tool Talk:

- Jim Ramsey had some ¼ Masonite panels if any body wants them
- Mike Jones purchased the tool pack that Jim Bany brought and Mike reports it's the best tool box he ever had
- Someone was curious what is the best biscuit jointer to purchase. Lamello is the best but the price is really high. The other notable would be the Dewalt biscuit jointer
- Someone is looking for a 20-inch thickness planer.
- Wayne Suter had a furnace blower for anyone who might want it for a dust filtration system.

Name tag door prizes

Howard Johnson wins screwdriver, Ken Grainger takes shop rags, Bob Wilson extension cord and Kevin McGuinness takes the scraper

Raffle:

Norman Rechlin wins the drill set, Don takes the wood chisel set, Mike Jones takes the forstner bits, James takes the scroll saw, Evan Doyle grabs the 10-piece drill set, David Roth wins the drill clamp and Trent Glamann wins the two-way clamp

Show and Tell:

Kevin McAndrew made a Time-Out bench for his daughter. Finished with sanding sealer and polyurethane. Kevin also used the Kreg Jig System.

Russ Amos Showed us a picture of his Kitchen cabinet rehab. made from pine. It was finished with Mohawk lacquer. The points of interest are the new door fronts and doors, plus one new cabinet. The challenge was applying the stain to the wood.

James Childress brought in two bird feeders made from redwood and western red cedar. He has a cedar tone deck finish, and the challenges were all the angles.

Calendar

Executive Meetings, 7:00pm Kansas City Public Library 1410 W 10th St. KC MO 64105

Guild meetings, 7:00 p.m., Jacob's Well Church, 1617 W. 42nd St., To reach us "during the meetings, call: KCMO. (816) 561-8177

Executive Meetings

Guild Meetings

2004

January 20th
February 17th
March 16th
April 20th
May 12th
June 9th
July 14th
August 11th
September 8th
October 13th
November 10th
December 8th

January 21st
February 18th
March 17th
April 21st
May 19th
June 16th
July 21st
August 18th
September 15th
October 20th
November 17th
December 15th

All members are welcome at any board meeting. A call to one of the Officers is all that is necessary.

Dave Kraatz brought in some full sized drawings of his teardrop Dulcimer. They are available for sale.

Jim Ramsey told us about his combo stand made from birch. It has a gel stain. This combo stand consists of a stand holding his miter saw and his portable thickness planer on one cart. This combo stand was also featured in American Woodworking Magazine. #109 September 2004.

Jim Bany brought in a Small parts bin cart made from birch plywood. It is 3 feet tall. The points of interest were all of the dado joints made for all the drawers. There are around 350 dado joints. Finished with Teak Oil.

Wayne Wainwright Showed the last of the flag cases from September 11th that were taken up to Iowa. Also he showed some 1-inch square blocks that he made for Project Eagle and generated \$100.00 for the guild. Wayne made 100 blocks.